

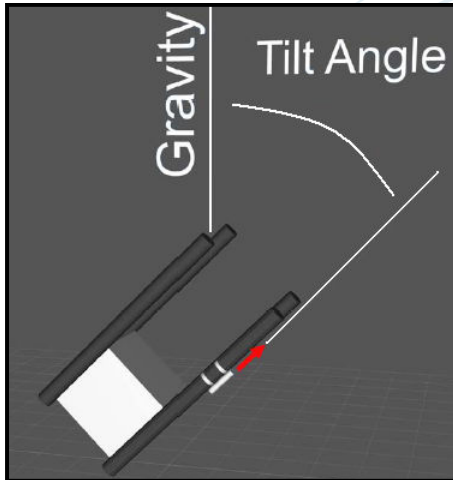

SONOTRONICS

EMT-AR Tilt Sensor Pingers



As seen in the image to the left, the pinger changes its ping rate proportional to the tilt angle with respect to gravity. This allows the orientation of equipment being deployed to be monitored in real time, while the pinger continues to mark the site for later relocation.



Deployments are monitored using either the USR-08 deck receiver or UDR diver receiver (right).



Understanding the System

EMT-AR pingers produce two separate sets of intervals (time between pings). One interval set is for unique identification of the pinger (fixed), and the other represents the angle of orientation relative to gravity (variable). The total time between successive angle measurements is approximately 30 seconds. The USR-08 receiver and DH-4 hydrophone from a MANTRAK kit, or UDR Underwater Diver receiver, is used to receive data telemetered from the tilt monitoring EMT-ARs. The receiver displays the ACT ID of the pinger, and tilt angle ($^{\circ}$) on its integral LCD. Tilt angle data has a 5° resolution, and a $\pm 5^{\circ}$ accuracy.



Model	Lifetime	Range	Depth rating	Length	Diameter	Weight
EMT-AR-1	48 months	1km+	2.5km+	99mm	19mm	39g
EMT-AR-2	18 months	3km+	2.5km+	99mm	19mm	39g
EMT-AR-3	To 6 mo*	To 4km+*	1km	201mm	32mm	252g
Other Model Numbers:						
TILT-Tracker	Tilt Monitoring kit. Includes MANTRAK kit, and two angle reporting tilt pingers. The MANTRAK kit includes USR-08 ultrasonic receiver, DH-4 directional hydrophone, Pelican case, external speaker, headphones, and other accessories. Please see the MANTRAK data sheet for more details.					

* parameters dependant on battery selection

SONOTRONICS

3169 S. Chrysler Ave. Tucson, AZ U.S.A. www.sonotronics.com
phone: (520) 746-3322 fax: (520) 294-2040 email: sales@sonotronics.com

Updated: 2/23/2010